

# Construction development of school furniture for developing countries

JAROSLAV ZACAL, MILAN SIMEK, PETR DOSTAL

Department of Technology and Automobile Transport, Faculty of Agronomy

MendelUniversity in Brno

Zemedelska 1, 613 00 Brno

CZECH REPUBLIC

xzagal@mendelu.cz

**Abstract:** Aim of this work is construction development of school seats for developing countries from locally available resources using the local industry and low-end technology. Functional school furniture contributes to basic comfort of pupils and therefore facilitates the learning process. Aim of diploma thesis is experimental assessment of mechanical properties of joints flexion in angular plane. Furthermore thesis considers assessment of joint firmness and comparison between various joint types. Thesis encloses the review of various joint manufacturing designs (tenon and mortise), which were proposed for its suitable mechanical properties and simplicity of manufacturing. Designated joint type is easiest form of joint construction and technologically feasible for chair manufacturing. The joints were constructed from fir wood (*Abies alba Mill*).

**Key-Words:** tenon, mortise, furniture construction, bending test, transversal plane, manufacturing technology

## Introduction

School seat construction from locally available resources is a priority for developing countries [1]. Leading advantages of this approach are shortening of supply chains, creating the maximal value of raw material and employing the local workforce in proximity of demand. Theoretical basis of this technology was proposed by [2], who implies the possibilities of application without sophisticated technologies. Method was tested in practice by [3]. Leading objective of this project was the design and practical construction of seats and chairs for schools in Zambia from locally available materials using the local industry and low-end technology. Design of simple wooden chair construction was performed using the “Greenwood chair” technology with use of manual woodworking tools commonly available in Czech Republic [4] introduces five basic schemes for furniture design. He favours the approach solving the joint dimensioning to safely withstand the internal forces as well as external load that affects the furniture in course of use. For simplification it is possible to claim that regardless of large scale of shapes each piece of furniture is basically designed using frame construction. One of fundamental perks for chair construction is the joint design. These joints have to be easily producible and composable. Therefore furniture design has to adapt the simple construction scheme and has to be adapted for use of simple manufacturing technology [1]. Fixation

system is supposed to facilitate the exchange of individual furniture components.

School seating furniture should be designed in most effective way considering the use of developing country resources and simultaneously to assure the optimal performance. Due to present economic status in education – not only in Zambia – one of leading aspects for consideration is the acquisition price of school furniture. That in certain levels affects both appearance and ergonomic characteristics and quality of school furniture.

It is expected that school furniture is designed for maximal lifespan, easy maintenance and repairs. It should also be easily composable from individual parts and designed as modular system with possibility to exchange the individual components in repair. Joints in the seating furniture could be manufactured as demountable without use of adhesives.

Another important factor for furniture construction are safety criteria, on whose basis the furniture has to achieve very high level of passive safety, considering both construction (stability, rounded edges, durability, joint sturdiness) and used material.

## Material and Methods

Construction material could be obtained from conventional sources, e.g. lumber from sawmills. Many parts could be obtained from wooden scrap; other parts could be manufactured from reused profiles like pallets, crates, cabinets etc. Another

option is purposive cultivation of fast-rotation coppice, whose thin trunk could be used as chair legs without subsequent turning.

*Abies alba Mill.* – This material, although not typical for designated country, was chosen for manufacturing of experimental samples for its mechanical properties. Namely for low flexibility module and different mechanical properties of earlywood and latewood. Mentioned properties helped adequately dimension the joint parameters to achieve the sturdy and durable connection of furniture components. Mechanical properties of *Abies alba Mill* wood helped to stimulate the use of low-quality material from local sources in developing countries and occasional technological mistakes in processing by incompetent staff. Despite these adverse factors the sufficient technical characteristics were achieved for proposed joints. Material available in target countries demonstrates the better mechanical properties, therefore is considered suitable for proposed use.

Manufactured testing samples represent the central joint used in seating furniture. For convenient manufacturing of tenon the plug cutter was used – it is a tool for cutting the plugs from transversal profiles for repairs of knot holes after drilling out the knot. Mortise was manufactured with forstner drill Fig. 1 which is a peripheral drillbit with segmented head consisting of two main edges, centering spike and two separate pre-cutters, which are easy to sharpen. Large opening for splinters in the drillbit extracts the splinters from the manufactured piece. Both these drillbits are used for drilling of the compact wood and also to drill out the loose knots or construction of simple tenon joints.

Fig. 1 Joint production scheme: (left) forstner drill bit – mortise, (right) plug cutter bit – tenon



### Sample description

Joint construction was performed in variants of round tenon/partial tenon and mortise as designated simplest and easy-to-manufacture type of chair component joint. The joints were manufactured from fir wood. Samples are constituted of two parts, which

were joined in T-shape. Samples were conditioned in air temperature  $24\pm 2^{\circ}\text{C}$  and  $50\pm 5\%$  relative air humidity. Length of tenon should relate to counterpart thickness in the manner of slightly overreaching the edge of mortise. Too long tenon needs to be trimmed. Round tenon overreaching the counterpart doesn't have sufficient sturdiness, because after hammering the wedge into the groove the wedge isn't inserted in its full length.

Fig. 2 Through tenon (sample A)

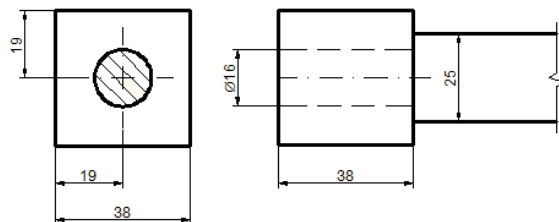

Fig. 3 Partial tenon (sample B)

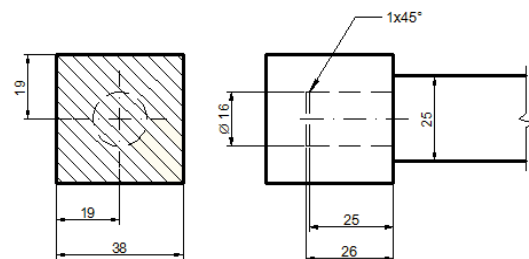
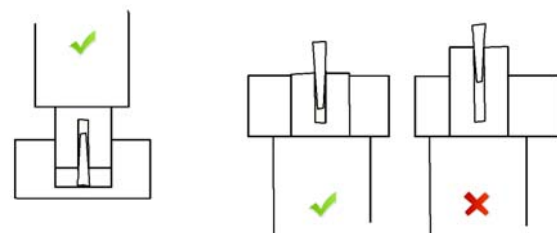

Fig. 4 Round tenon



Legend: Partial tenon  
Joint performance (left) correct (right) incorrect

### Testing method

Experimental testing of furniture joints in industry was performed by [4] and [5] their research was focused on simple joints like pin, tenon and mortise for frame construction of massive wood. Experiment is designed to assess the joint behaviour in transversal plane, its sturdiness and shift under pressure with regard to parameters of designated material. Methodology of experiment was used according to [5] for assessment of joint sturdiness in transversal plane. Despite the lack of valid technical standard the method is commonly used for mutual comparison of testing results. Method was further used by numerous

authors e. g. [6, 7]. Testing was performed on Universal Testing Machine (SHIMADZU UH-300kNA). From previous experiments the optimal velocity of 10 mm/min was deduced to achieve the maximum load in  $90\text{ s} \pm 30\text{ s}$ . Method of experiment was used as described by [5]. Testing samples were divided into 8 groups. Groups no. 1 and 4 were manufactured with round tenon and groups no. 5 and 8 were constructed with partial tenon Tab. 1. For comparison of measured values the control samples were manufactured with use of adhesive and without the wedge, where final sturdiness correlates to D2 adhesive class. The joint was constructed as tenon and mortise, whose main feature is the time and cost efficiency of firm joint construction. Use of wedge for fixing the components appears as a rational alternative in conditions eliminating the possibility of the use of adhesives.

Table 1 Groups of tenon samples

Type of joint		dimension in mm	Numbers of samples
With wedge	D	25x38	12
	C	25x38	12
	B	25x25	12
	A	25x25	12
With glue	D	25x38	5
	C	25x38	5
	B	25x25	5
	A	25x25	5

Fig. 5 Scheme of fastening the samples in testing device

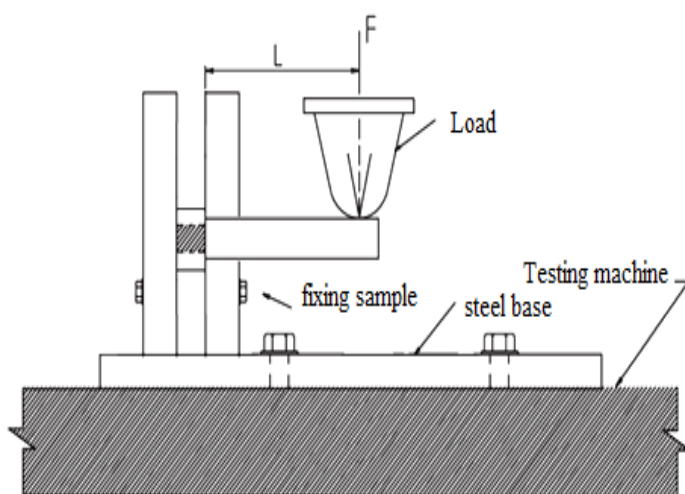

## Results and Discussion

Table provides direct comparison of resulting firmness for individual sample types. Mentioned results and firmness division are described also by Angular coefficient 10–40%. In the experiment it is necessary to take into account the thickness of adhesive layer, material type, roughness of glued surface or component preparation previous to gluing. According to Tab. 2 there are obvious differences between glued and unglued samples. In second phase of the measurement the results indicated higher sturdiness for round tenon and round trestle.

Table 2 Angular coefficient 10–40%

Type of joint	Unglued (wedge)	Glued
A	$y = 132,9x + 0,330$	$y = 242,5x + 0,446$
B	$y = 131,5x + 0,526$	$y = 152,9x + 1,419$
C	$y = 140,7x + 0,860$	$y = 166,8x + 0,859$
D	$y = 153,9x + 0,306$	$y = 266,8x + 0,323$

For designing the optimal variant of joining the components the least favourable condition of stress should be taken into account, in our case the variant with least sturdiness and durability was achieved in impassable tenon. In my opinion it is best to discard these joint types for technical difficulty in manufacturing, therefore these variants are not further considered. For comparison data measured by [5] and [7] were used, who performed the same testing with application of adhesive and different dimensional parameters of joint stressed in angular plane. Result comparison is interpreted in Tab. 3.

When comparing results for carrying capacity in variants samples A glued / unglued – 31.78 / 28.35 N·m (difference 3.43 N·m) and samples C glued / unglued – 35.14 / 32.69 N·m (difference 2.45 N·m), the setup of joints is in this case very similar. In comparison with results published by [5] for dependency between carrying capacity in angular plane and tenon width, it is obvious that tested samples have higher carrying capacity compared to spruce wood samples. This claim ensues that used non-glued (wedged) and glued samples achieve the sufficient carrying capacity in angular plane and this setup is suitable for required parameters.

In comparison with results reviewed by [7] it is not possible to compare the data in full scale. Estimated experiment assessed the mechanical properties in angular plane using the PVAc adhesive N203, where final sturdiness values correspond to D3 class for populus and fagus wood.

Table 3 Measured values in angular plane according to various authors.

Author	Through tenon/ Variant	Wood	Length of tenon in mm	Bending moment in N·m	Glue / recommended values
Kamperidou [7]	Through tenon	Fagus	30	91.42	PVAc N203 (D3)
		Populus	30	44.38	
Joščák [5]	Through tenon	Fagus	40	48.76	recommended values
		Picea abies	40	23.07	
With glue	A	Abies alba	38	31.78	PVAcRakoll (D2)
	C	Abies alba	38	35.14	
With wedge	A	Abies alba	38	28.35	
	C	Abies alba	38	32.69	

The results also imply the necessity to take into account the effect of adjacent lever arm of sample when pressed against the counterpart Fig. 6. Previous experiments confirmed the effect of lever arm, where round tenon samples C, D with dimension 25 x 38 mm shows higher values of carrying capacity. The results show that adjacent lever arms could substantially enhance the joint sturdiness. This confirms the theory of “inner arm effect” in the sample on final sturdiness value.

If the inserted piece has sufficient area to lean against the counterpart in course of stress, the tension shows directly in the joints, resulting in deforming the mortise and breaking / pulling out the tenon.

Construction of joints affects not only the final piece, but in construction and furniture manufacturing it is important to pay attention to manufacturability and most importantly the usability of finished piece. The sturdiness of joints depends on tenon diameter, inserting depth into the counterpart and also on material used. Influence of variable joint length correlated with its constant diameter is significant for its sturdiness. In prevalent cases there is an effort to achieve the maximal length and diameter of tenon to ensure the best sturdiness characteristics.

Joints manufactured in this experiment were used to dimension the simple construction method to achieve the required sturdiness.

Fig. 6 Representation clingy arm

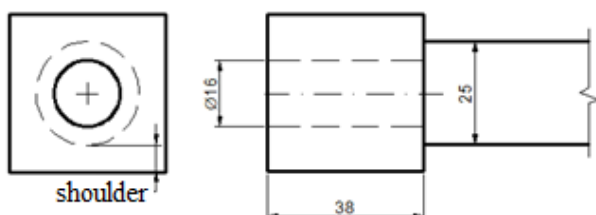

### Chairs construction

In real development of particular product it is necessary to first manufacture the functional prototype Fig. 7. Then the individual details are considered and altered, including the exact dimensions and proportions of final product, as well as its individual parts. Prototype is often manufactured with some compromises like financial budget. For these reasons it is necessary to consider the final documentation with tolerance. It is possible, that the final product will be further modified.

Fig. 7 Chair documentation

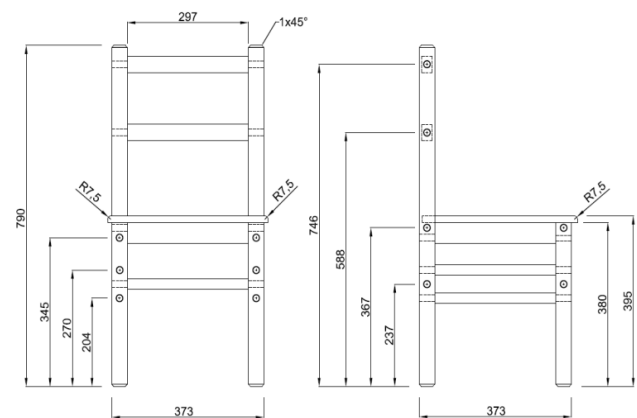

### Conclusion

Aim of this work was the design of constructing solution for school furniture in Zambia, manufactured by local industry from locally available resources and employing the low-end technology. The hypotheses are following:

- Is it possible to manufacture the school furniture from locally available materials?
- Is technologically possible to simplify the manufacturing processes in scale allowing
- the local production of the furniture in target



- developing countries?

First I was looking for a simple way to produce furniture in our history. With advancing my knowledge of given issue I found out a possibility to manufacture the seating furniture with use of simple „Greenwood chair“ construction using only the simple woodworking tools.

Considering the material it is possible to produce the school furniture from wood scraps, old pallets or pickets from forest thinning. Parts required for construction could be cut from sawmill trimmings.

In realisation the main objective was to create the economically available and easy-to-produce seating furniture. Material and energy costs invested in furniture production should reflect its durability and lifespan. Therefore it is necessary to maximize the lifespan and utility value in design and production.

Possibility of replacement of individual construction elements decreases the amount of material needed for chair repairs and in a certain manner facilitates the manufacturing process. These advantages allow to repair the construction in case of turning the joint loose.

In chair construction the broad spectrum of tenon joints is used. This type is regarded as one of the oldest ways of seating furniture joints solution and simultaneously it is regarded as the most efficient due to its sturdiness characteristics. In spite of construction design diversity it is not possible to judge that one joint solution is inadequate or less sturdy than another, because the position of joint in construction is always a determining factor. Experiment was aimed on joint durability and carrying capacity measurement angular plane, as well as its resistance to turning. Length of tenon affects the joint durability. In performed tests better sturdiness characteristics in round tenon trestle, samples A, C were found, which show better sturdiness compared to partial tenon variant. Further the acquired data show that technological and temporal expenses of partial tenon construction variant are undesirable.

Use of these joints produced with low-end technology displays a great potential for developing countries; it is considered to be one of the easiest joints to produce, not requiring any qualification to assemble.

## Acknowledgement

The research has been supported by the project TP 4/2014; Analysis of degradation processes of modern materials used in agricultural technology; financed by IGA AF MENDELU.

## References:

- [1] Havierova E, Eckelman CA, Erdi, Y, *Design and Testing of Environmentally Friendly Wood School Chairs for Developing Countries*. Forest Prod. Journal. No. 51, 2001, pp. 58-64.
- [2] Alexander J, *Making a Chair from a Tree: An Introduction to Working Green Wood*. Mendham, NJ, USA: Astragal Press, 1994, pp. 133.
- [3] Eckelman CA, *Textbook of Product Engineering and Strength Design of Furniture*. Purdue University 2003, pp. 30-42.
- [4] Eckelman CA, *Engineering Design of Dowel Joints*. Station Bulletin Purdue University, West Lafayette, Indiana, No 745, 1997, pp. 32.
- [5] Joščák P, *Pevnostné navrhovanie nábytku. 1. vyd. Zvolen: Technická univerzita vo Zvolene, 2000, 246 s.*
- [6] Vassiliou V, and Barboutis I, *Tension strength of furniture middle joints constructed with biscuits*. Proceedings of International Scientific Conference “10th Anniversary of Engineering Design (Interior and Furniture Design)”, Sofia 2005, pp. 17-18.
- [7] Kameridou V, Vassiliou V, *Bending Capacity of Middle Joins of Upholstered Furniture Frames*. Drvna Indutrija 2012, pp. 63.